

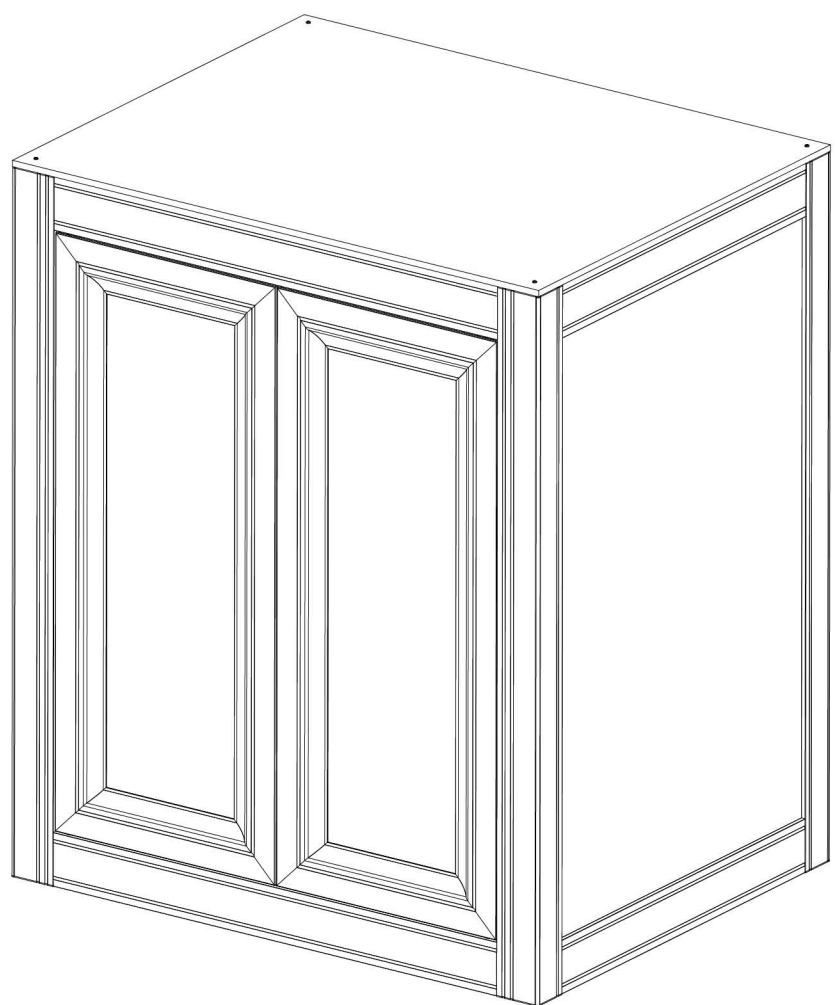

ASSEMBLY MANUAL

For Models
03050 | 0405 | 0505 | 0605 | 0707



We would like to take a moment to say Thank You for supporting Innovative Marine. We know you are excited to get your dream scape up but if we can take a moment, we would like to introduce the NUVO APS and why specific features were included in the construction of this stand.

The term APS is an acronym for Aluminum Profile Series. These series of aluminum stands were created to address major issues with current stands used in our hobby.

Our goal, to set a new standard on how aquarium furniture should be constructed with these key features in mind: Sturdy and strong, lightweight, resistant to corrosion and swelling, modular and easy to set up and finally aesthetically pleasing.

We've looked and found inspiration from industries outside our hobby and found that aluminum has been a tried and true element for commercial fixtures for decades because of its versatility and strength.

We've brought and re-engineered this technology into our hobby and crafted a sturdy, easy to setup, eye pleasing platform that showcases your reef.

We want you to be completely satisfied with your purchase.

If there is anything that did not meet your expectations, please contact us.

866-368-7941 or warranty@innovative-marine.com

Once again thank you for choosing Innovative Marine and welcome to the IM family.

How to assemble your APS stand:

Each profile has tension locks pre-installed and on each tension lock has a pre-molded dot to be used as a visual indicator. The visual indicator allows you to see if each profile is in the unlocked or locked position.



To ensure security and stability of the stand please make sure each tension lock has been set in the locked position before placing any weight upon it.

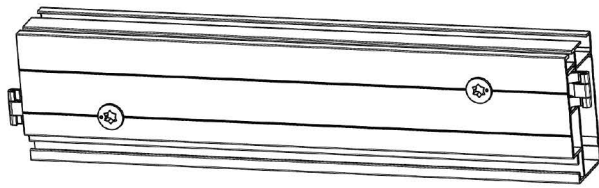
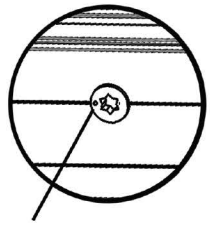

← If the "Dot" is facing away from the center of the profile it is in the unlocked position →

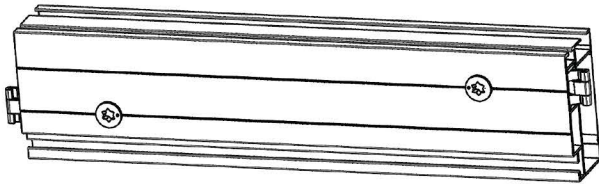
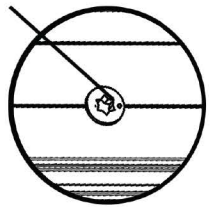

→ If the "Dot" is facing towards the center of the profile it is in the locked position ←

When assembling the stand the profile's tension locks utilize the smaller channel.

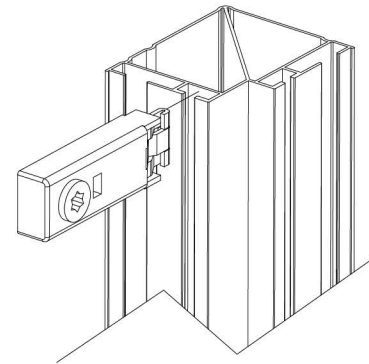
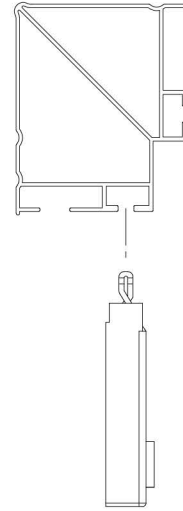

Locked position

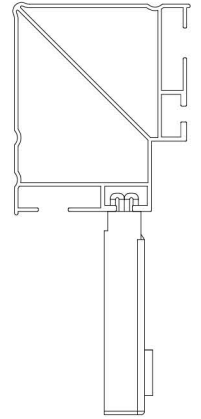

To securely lock each profile into position, insert the supplied hex torque wrench into the tension lock and turn clockwise.

Unlocked

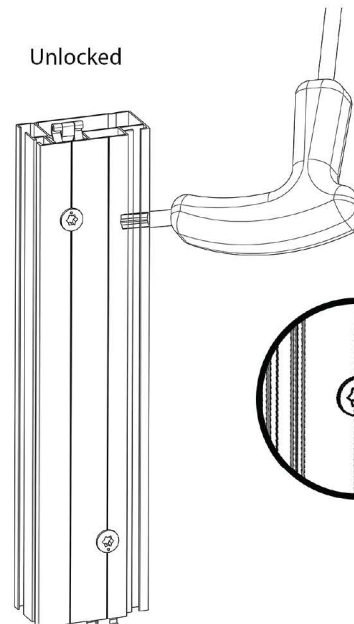

Locked

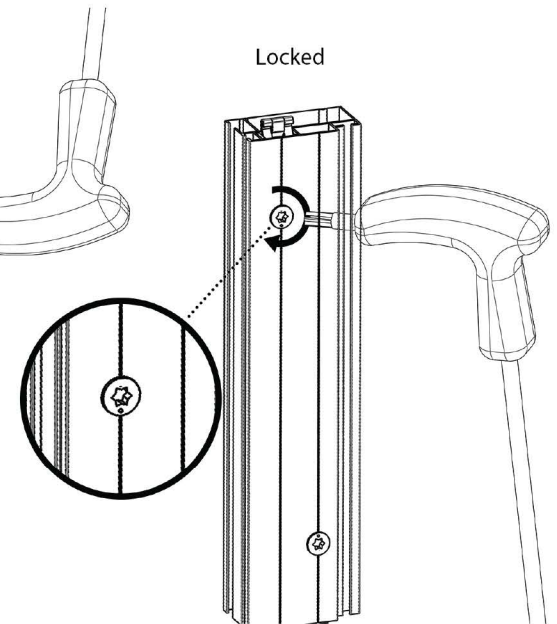

For Models
03050 | 0405 | 0505

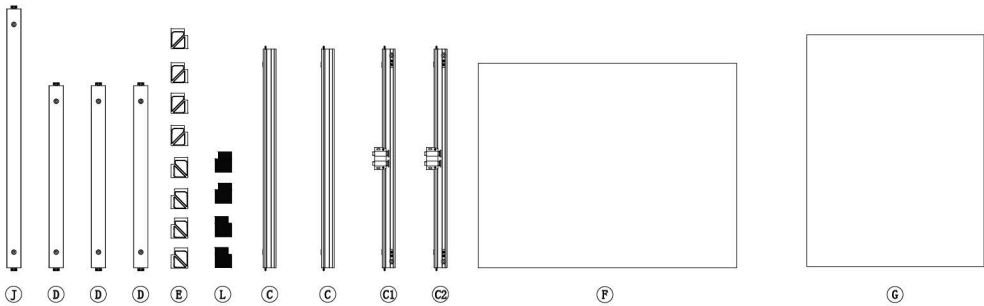
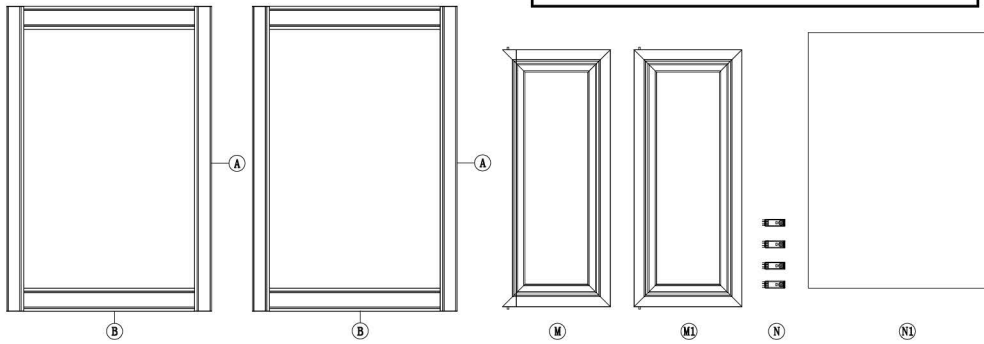

A/B	2 x Left and Right Side Profile Frame
M	1 x Door
M1	1 x Door
N	4 x Shelf Locks
N1	1 x MDF Shelf
J	1 x Vertical Rear Profile
D	3 x Horizontal Cross Profile
E	8 x End Caps
L	4 x Pre-Cut Rubber Feet
C	2 x Top or Bottom Rear Profile
C1	1 x Bottom Front Profile
C2	1 x Top Front Profile (APS Logo)
F	1 x Top PVC Foamboard
G	1 x Bottom Board

Also included inside APS Stand Box

- 1 x Hex Torque Wrench
- 4 x Phillips Head Screws

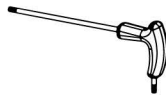

Additional Tools Needed (Not Included)

- 1 x Phillips Head Screwdriver



For Model
0605 | 0707

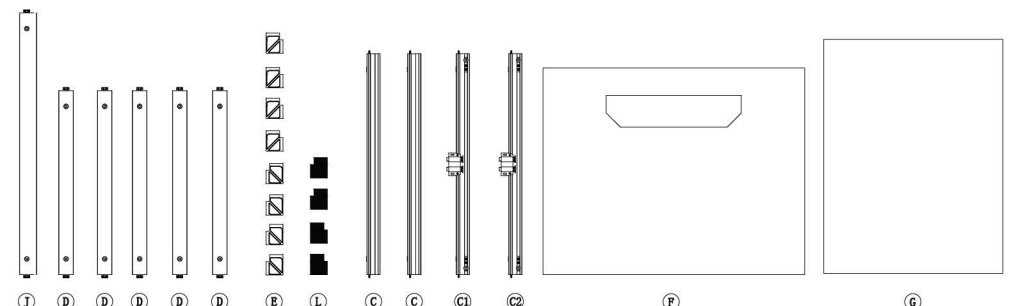
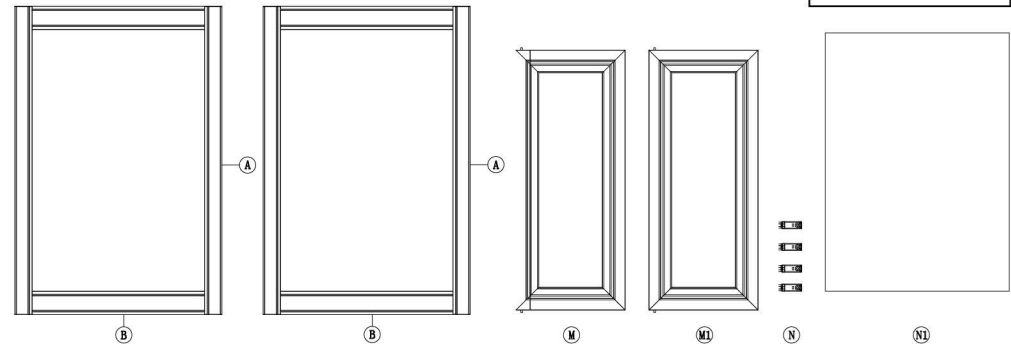

A/B	2 x Left and Right Side Profile Frame
M	1 x Door
M1	1 x Door
N	4 x Shelf Locks
N1	1 x MDF Shelf
J	1 x Vertical Rear Profile
D	5 x Horizontal Cross Profile
E	8 x End Caps
L	4 x Pre-Cut Rubber Feet
C	2 x Top or Bottom Rear Profile
C1	1 x Bottom Front Profile
C2	1 x Top Front Profile (APS Logo)
F	1 x Top PVC Foamboard
G	1 x Bottom Board

Also included inside APS Stand Box

- 1 x Hex Torque Wrench
- 4 x Phillips Head Screws

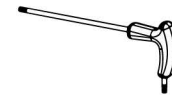

Additional Tools Needed (Not Included)

- 1 x Phillips Head Screwdriver
- 1 x Box Cutter

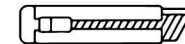

1.) Attach the end caps (4 x E) to open ends of left and right frame. (A & B).

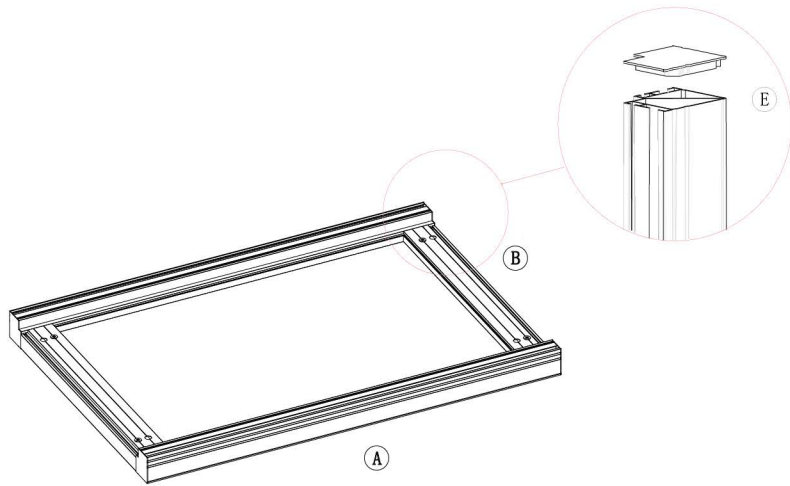

3.) Attach Bottom Front Profile (C1) to (A & B) and lock into place.

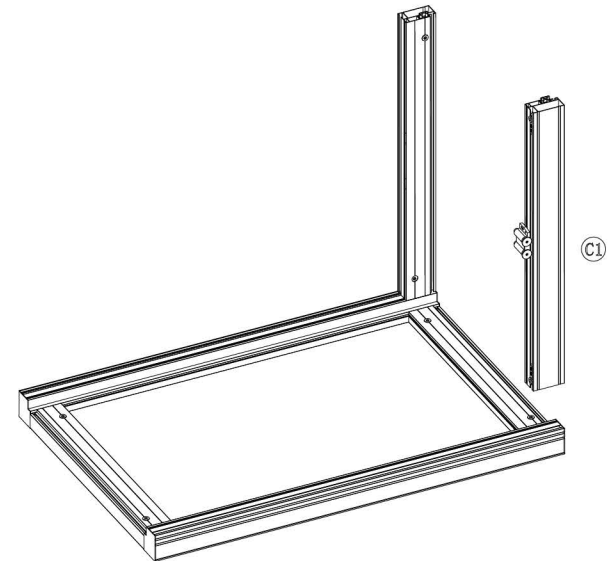

2.) Attach Top or Bottom Rear Profile (C) to (A & B) and lock into place. Make sure the profiles line up with the end caps.

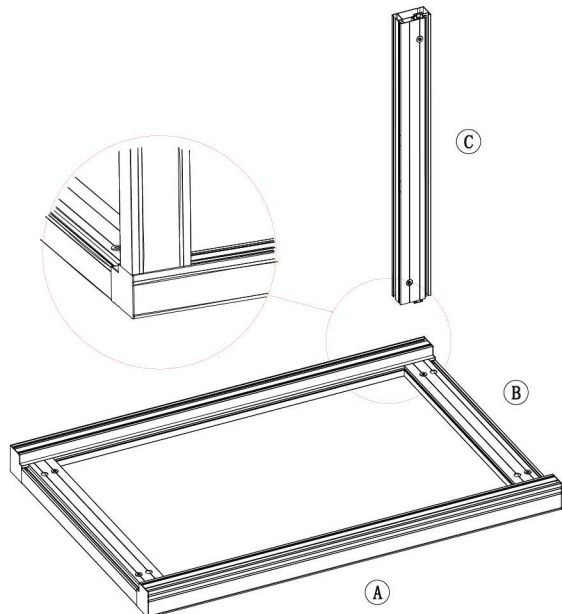

4.) Attach Horizontal Cross Profiles (2 x D) to (A & B) and lock into place.

Follow this step if assembling the 03050, 0505 or 0405 stand.

Then proceed to step 5.

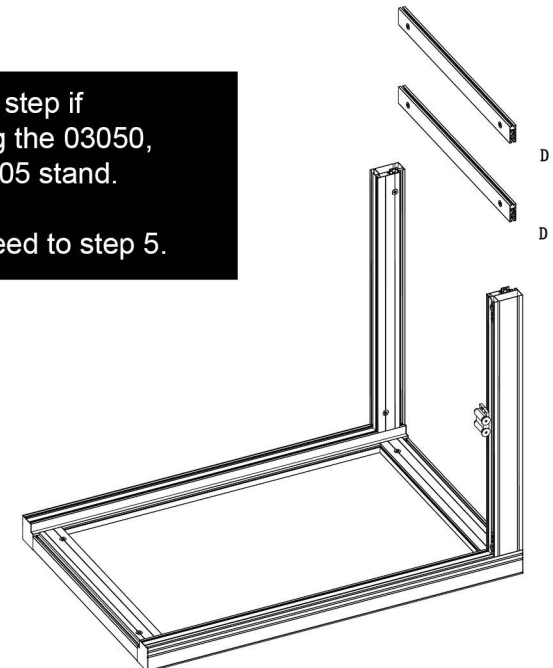

4.) Attach Horizontal Cross Profiles (3 x D) to (A & B) and lock into place.

Follow this step if assembling the 0605 or 0707 stand.

Then proceed to step 5.

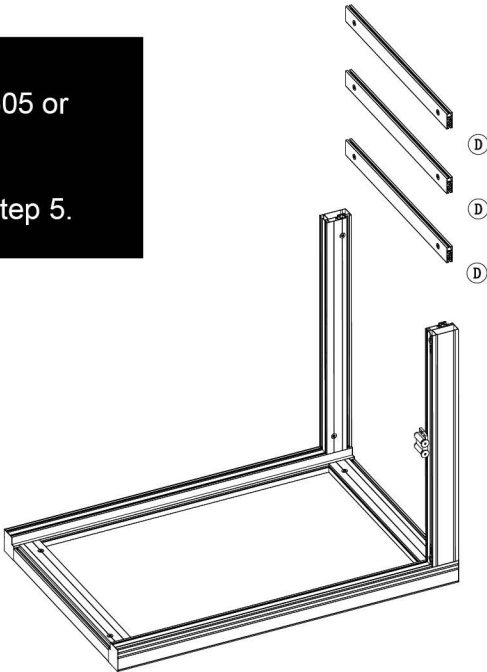

6.) Attach Top Front Profile (C2) to the top of (A & B) and lock into place.

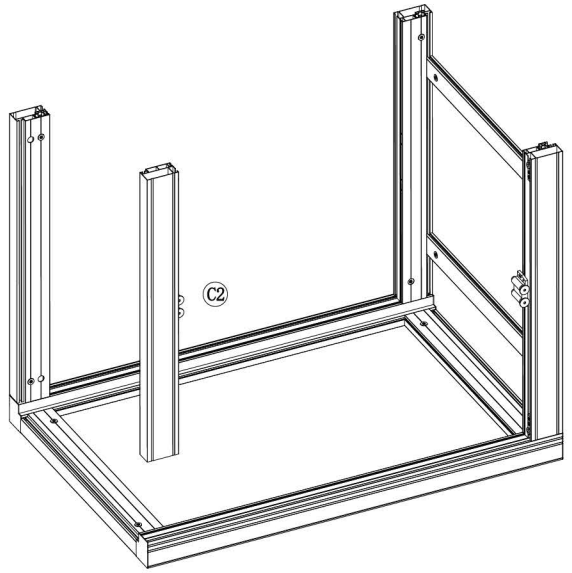

5.) Attach Top Profile (C) to the top of (A & B) and lock into place.

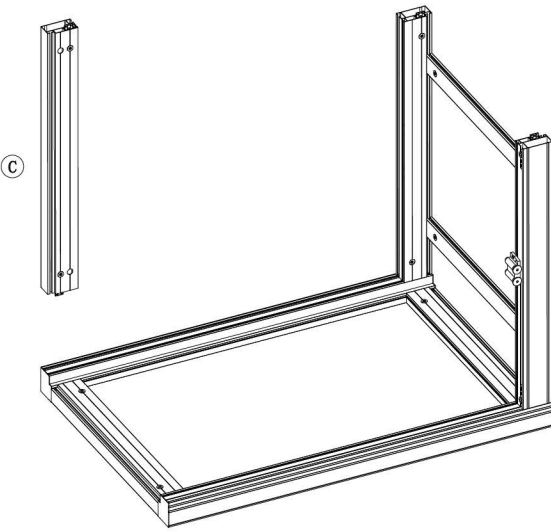

7.) Attach Horizontal Cross Profiles (D) between (C and C2) and lock into place.

Follow this step if assembling the 03050, 0505 or 0405 stand.
Then proceed to step 8.

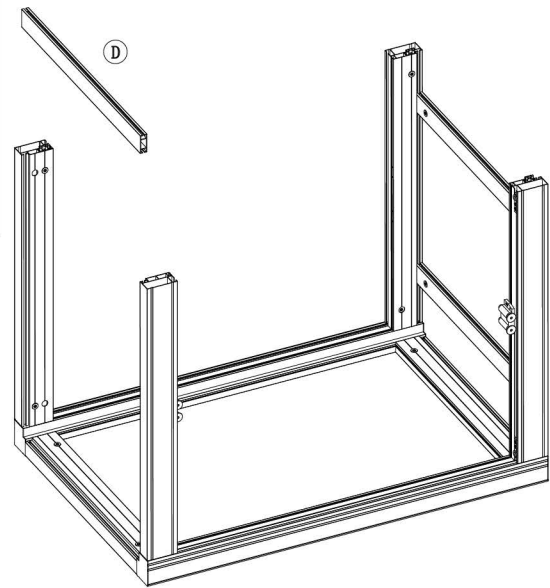

7.) Attach Horizontal Cross Profiles (2 x D) between (C and C2) and lock into place.

Follow this step if assembling the 0605 or 0707 stand.
Then proceed to step 8.

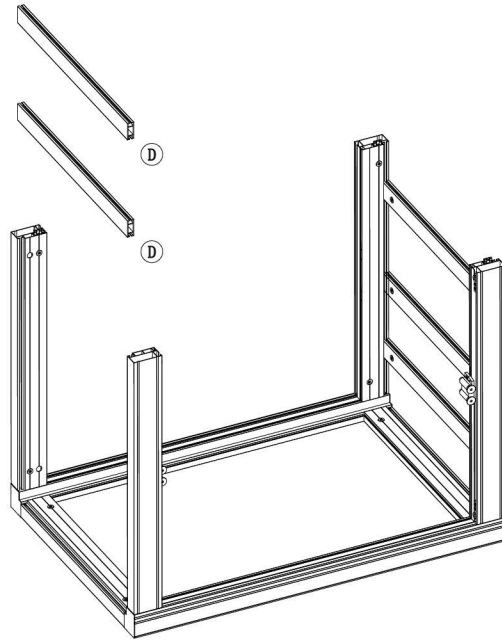

8.) Attach Vertical Rear Profile (J) between (C and C) and lock into place.

Insert top of profile first

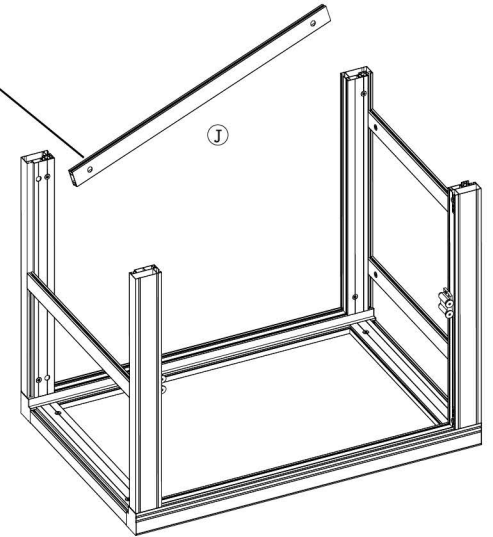

9.) Attach (A & B) to the frame and lock into place.

These profiles need to be 14 inch apart to ensure proper space for INT piping.

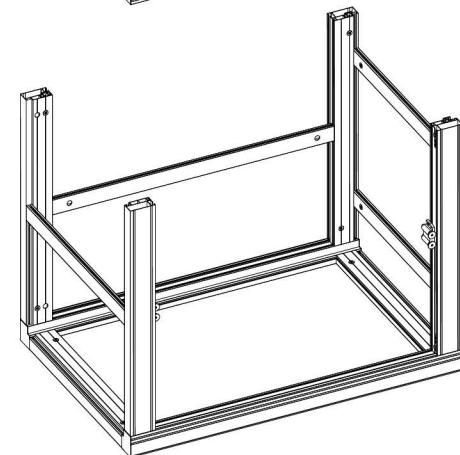
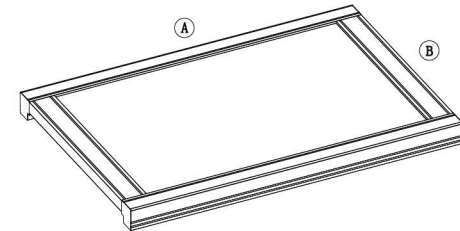
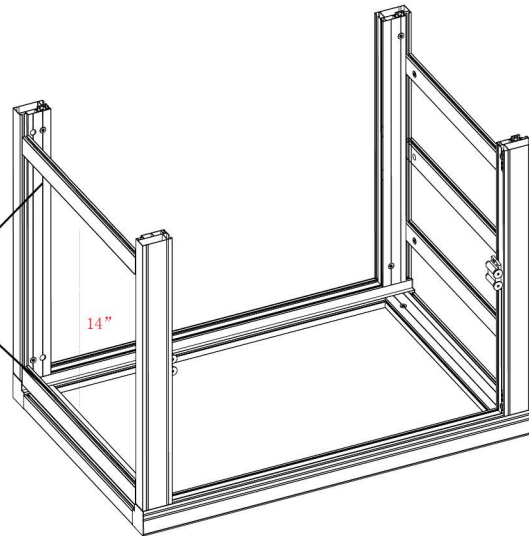

10.) Peel the adhesive backing off the rubber feet (4 x L) and adhere them to the end caps.

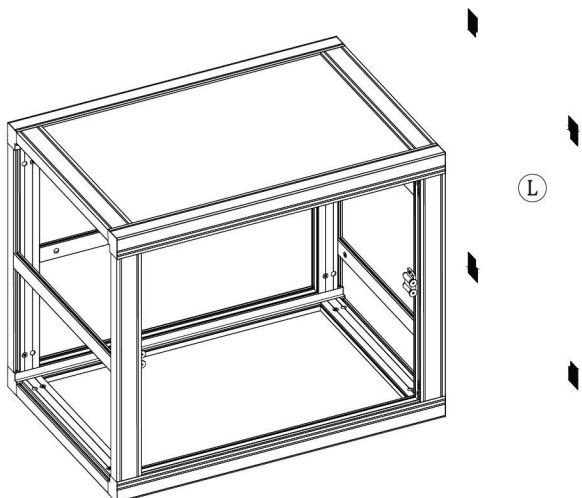

12.) Insert Bottom Board (G).

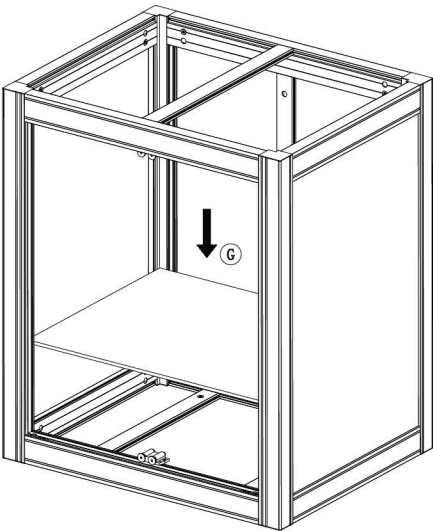

11.) Flip stand onto its base and make sure all profiles are locked and stand is level.

If stand is not level, loosen and move profiles to readjust.

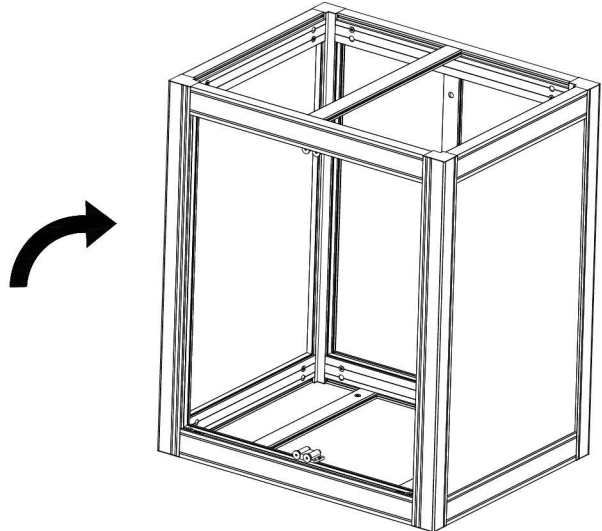

13.) Insert shelf locks (4 x N) into the smallest channel on the profile.

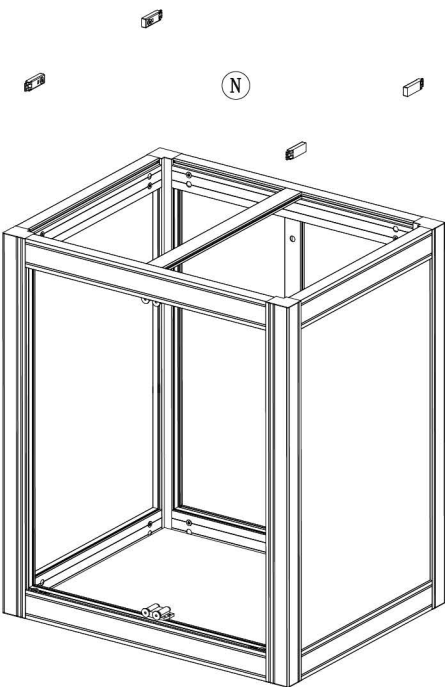

14.) Secure shelf locks (4 x N) to stand and place the shelf (N1) atop of them.

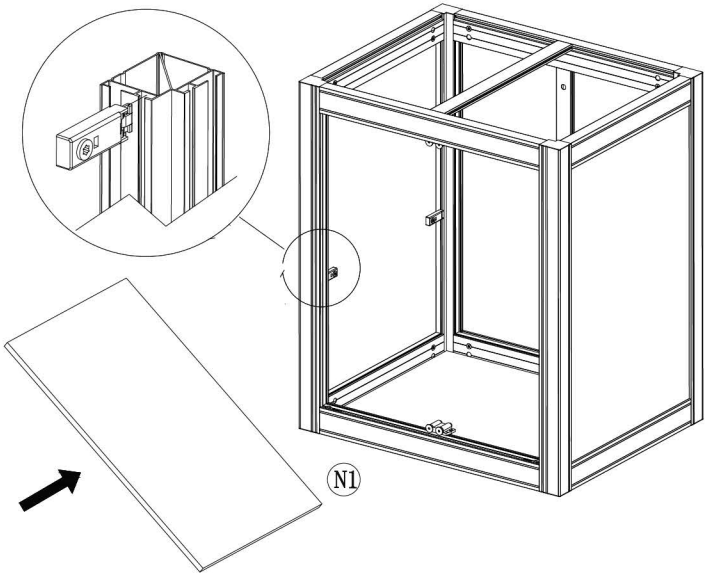

16.) Insert the door (M) into the white pivot brackets. Slide the door to the left and tighten top and bottom pivot brackets using a phillips head screwdriver.

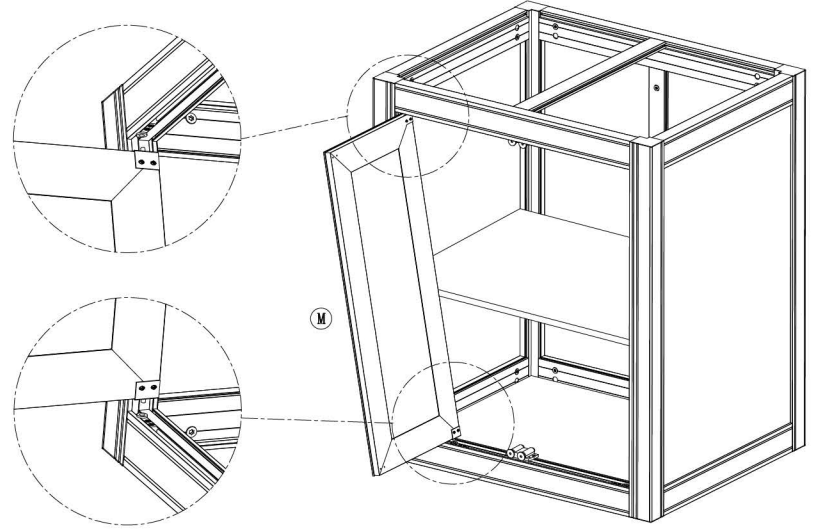

15.) Test to see if shelf is level.

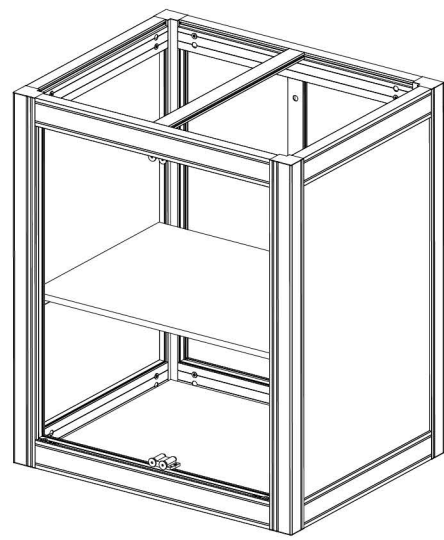

17.) Repeat step 16 with door (M1). Slide the door to the right and tighten top and bottom pivot brackets using a phillips head screwdriver.

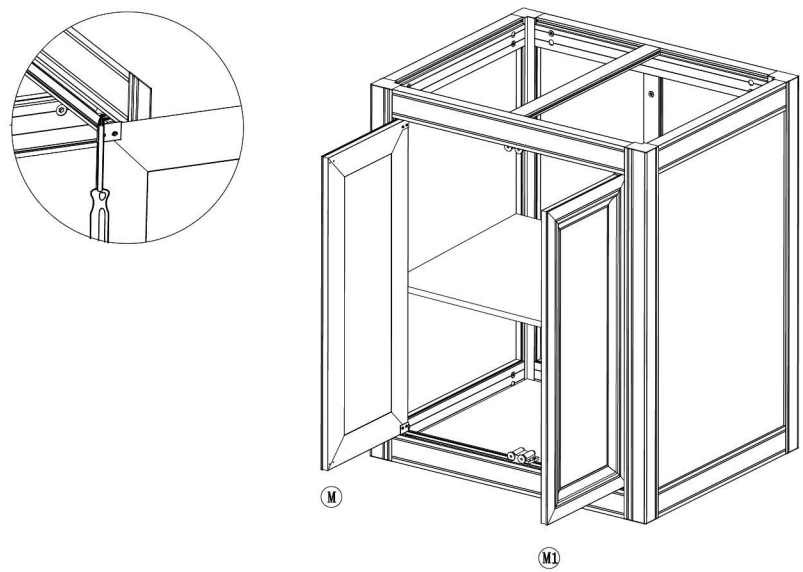

18.) Screw panel (F) into the end caps with the provided 4 x phillips head screws.

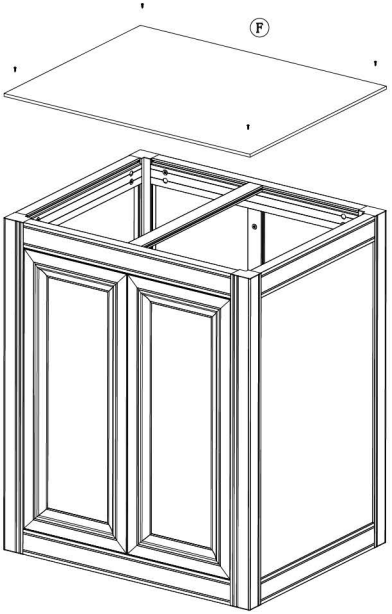

20.) Using a box cutter, cut and remove the pre-scored hole on panel (F)

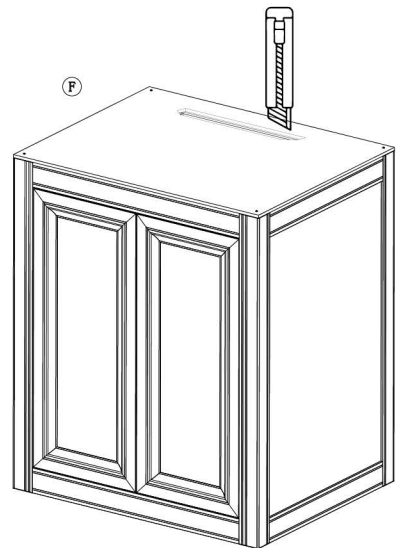

19.) Check once again to make sure all profiles are securely locked then place aquarium atop the stand.

21.) Check once again to make sure all profiles are securely locked then place aquarium atop the stand.

If you are assembling the 0707 stand. Do not place aquarium atop stand and proceed to step 20.

