

Thank you for purchasing your new SKIMZ Calcium Reactor that provides optimum performance with maximum safety and reliability.

Model	Body Diameter (mm)	Recommended Feed Pump	Feed Inlet Diameter	For Aquarium	Code
CM 122	120	300 - 500 l/hr	1/4" (6.35mm)	up to 1000 L	8017-00
CM 152	150	500 - 1000 l/hr	1/4" (6.35mm)	up to 1500 L	8018-00
CM 202	200	1200 - 2000 l/hr	1/4" (6.35mm)	up to 2500 L	8019-00
CM 202H	200	1200 - 2000 l/hr	1/4" (6.35mm)	up to 5000 L	8040-00

SAFETY INSTRUCTIONS

Check that the voltage shown on the label of the pump corresponds to the voltage of the main supply.

Disconnect all electrical appliances from the main before placing your hands in the water.

The pump is protected against overheating. Never allow the pump to run dry.

MAINTENANCE

It is recommended to clean the pumps every 3 months. Check and clean the impeller, and if necessary soak the pump and impeller in white vinegar to dissolve any calcium deposits.

The CO2 flow rate and the effluent drip rate through the reactor have to be checked regularly. Occasionally, you might find it necessary to open the effluent valve all the way to clear any build-up, and then adjust it back to normal. If you notice that the effluent drip rate is not holding constant flow, remove the valve and clean it thoroughly under some warm water.

WARRANTY POLICY

Skimz Singapore LLP (Company) warrants this product to the original purchaser against defective material and workmanship that occurs during normal use of the body for two (2) years and one (1) year warranty on the pump. Company will, at Company's option, either repair or replace without charge.

PRODUCTS COVERED BY WARRANTY

All Skimz equipment is covered by warranty from the date of purchase. To be effective, register your product at: www.skimz.sg/support/register.html within 14 days of the product's purchase date.

Exclusions:

Damage resulting from accident, misuse, lack of reasonable care, subjecting the product to abnormal working conditions or any other failure not resulting from defects in materials or workmanship.

Damage caused by tampering, modification or attempted repair by anyone other than the Company.

Transfer of product to someone other than the original purchaser.

Bring the product to your nearest Skimz dealer or ship the product, together with a copy of the purchase receipt or other evidence of purchase to:

Skimz Singapore LLP
5 Ang Mo Kio Industrial Park 2A
#04-30 AMK Tech II
Singapore 567760

You must pay any postage, shipping charges, insurance costs and other expenses to return the product to Skimz. However, if the necessary repairs are covered by the warranty, Company will pay the return shipping charges.

This product is qualified in accordance with the respective regulations and guidelines and meet EC standards.



QUICK INSTALLATION GUIDE

Monzter E-SERIES



CM 122
CM 152
CM 202
CM 202H

dual-stage CALCIUM REACTOR



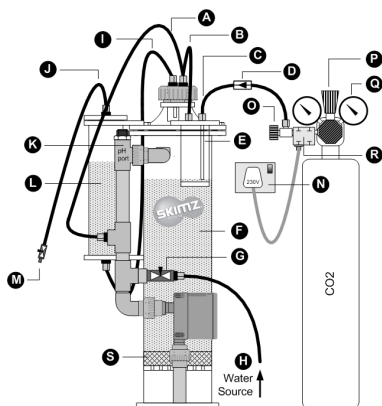

- A. CO2 recirculation
- B. CO2 inlet to reactor
- C. CO2 inlet to bubble counter
- D. Check valve
- E. Bubble counter
- F. Calcium media
- G. Water inlet 1/4" speedfit with shut-off valve
- H. Water from aquarium
- I. Water outlet to second chamber
- J. Water outlet to sump tank
- K. PH port
- L. Second chamber
- M. Water outlet valve (effluent)
- N. Power plug
- O. CO2 Solenoid needle valve
- P. CO2 pressure adjustment valve
- Q. CO2 output pressure gauge
- R. CO2 Solenoid
- S. Sponge

STEP 1

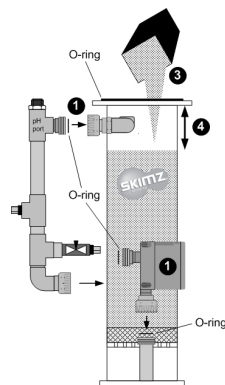

1. Assemble the reactor pump and tighten all union connections as shown on the diagram.
2. Before starting, thoroughly rinse the calcium media with freshwater to remove any fine dust.
3. Unscrew the lid and pour calcium media into the reactor chamber. You may add 10% of magnesium media (dolomite) to maintain magnesium levels.
4. Leave about 3 inches of free space between the top of the reactor and the media. Do not overfill the reactor, media could get sucked into the pump intake.
5. Make sure there is no debris from the media on the o-ring before you replace the lid as this will break the seal. Ensure that the o-ring is in position and tighten the lid onto the body.

STEP 2

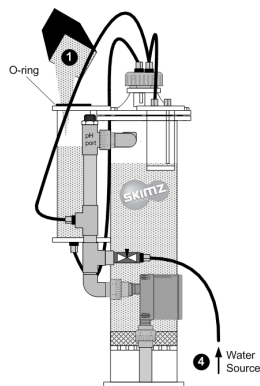

1. Unscrew the lid of second chamber and fill with calcium media up to 3/4". The calcium media in the second chamber is to scrub off any extra CO2 and buffer the pH before it goes into the tank.
2. Alternatively, you may consider filling it with phosphate remover media as most calcium media available are of natural sources, there are considerable amount of phosphate in these products.
3. Tighten the lid onto the second chamber, having first checked that the o-ring is in position.
4. Using the 1/4" OD tube supplied, connect the water inlet to the water source.

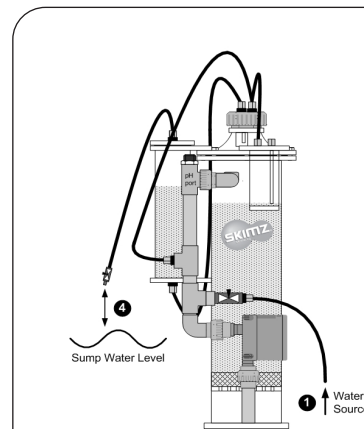

STEP 3

1. The calcium reactor must be supplied with water from the aquarium. There are different ways to choose the water source:
 - a. Run a supply from feed pump
 - b. T off an existing pump
 - c. Using a peristaltic pump
 - d. Gravity feed
2. If you are using peristaltic pump, you can open the water inlet and outlet valve fully as the peri pump will control the flow rate.
3. Using option a. and b. is a more reliable way of feeding a calcium reactor. Install a hose reducer to the pump outlet.
4. Position the water outlet valve several inches above the water line in the sump.

STEP 4

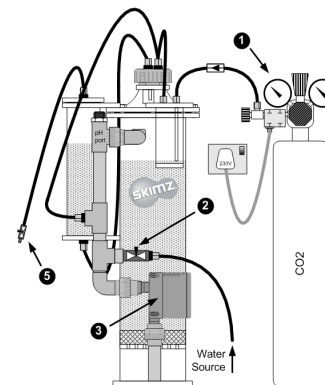

1. Connect the CO2 equipment as shown on the diagram. Place the check valve between the reactor and the CO2 tank. Verify that the arrow is pointing in the direction of CO2 flow.
2. Open the water inlet valve and turn on the feed pump.
3. Once the chamber has filled with aquarium water, switch on the calcium reactor pump.
4. Let the reactor run for 5 to 10 mins or until the water inside the chamber clears. The bubble counter should fill with water automatically. Verify that there aren't any leaks.
5. Once the water is flowing back to the sump, adjust the outlet valve until the drip rate is 1 drip per second.

STEP 5

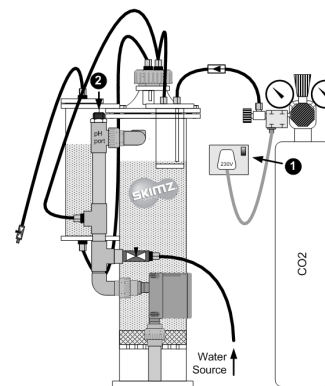

1. Switch on the CO2 and slowly open the secondary valve until gauge reads 15 PSI. Next, set the flow rate to 1 bubble per second.
2. If you are using a pH controller, remove the plug from the pH port and install the pH probe. Set the controller to keep the pH in the reactor between 6.6 to 7.0.
3. Once the reactor has been set up, you need to fine tune the flow of CO2 and effluent to match your aquarium demand. A range of 7-11 dKH alkalinity and 375 - 450 ppm calcium is considered acceptable.
4. Write down the results and test your aquarium's calcium and alkalinity levels. If these levels are rising above, you should slow down the flow of CO2 and effluent drip. If these levels are falling, adjust the flow higher.